



THE PLUS ALLIANCE

PHOENIX | LONDON | SYDNEY

Global communities empowered
through innovative and accessible
education and research

2021 Snapshot



ABOUT THIS SNAPSHOT

This document provides examples of the collaborative work of the PLoS Alliance.

These accomplishments are the result of the concerted efforts and a sustained drive for excellence by executives, Fellows, academics and the students at the PLoS Alliance universities.

The Presidents at Arizona State University, King's College London and UNSW Sydney and the international PLoS Alliance Advisory Board have contributed resources, expertise and time to realise these successes.

We also thank the many external partners and friends who have made, and continue to make, the PLoS Alliance vision of a fairer and more sustainable world possible.

Table of contents

01	A Unique Global Partnership	p. 04
02	Our Strategic Priorities and Team	p. 05
03	TEDI-London	p. 06
04	Collaborative Research	p. 07
05	Sustainability	p. 08
06	Global Health	p. 10
07	Social Justice	p. 12
08	Emerging Themes	p. 13
09	Education	p. 14
10	Global Engagement	p. 15
11	Celebrating Excellence	p.17

A UNIQUE GLOBAL PARTNERSHIP

As a more interconnected and interdependent world looks for new ways to innovate and prosper, the PLuS Alliance uniquely brings together three leading universities – Arizona State University, King’s College London and UNSW Sydney – to pursue solutions to global challenges via collaborative research and creative, technology-enabled learning. The PLuS Alliance’s vision is: **Global communities empowered through innovative and accessible education and research.**

INNOVATION AND IMPACT DRIVE OUR WORK

This is an alliance like no other. Three of the world’s truly outstanding universities from different geographies but with complementary capabilities have joined forces to improve the world through solutions-focused research and dynamic education programs. The PLuS Alliance represents a significant shift from traditional 1+1 university partnerships and memberships of national and international networks.

The Alliance is under no illusions that deep, value-adding collaborations between universities can be difficult, but at the same time we are driven to think and act more creatively and courageously. TEDI-London is the Alliance’s joint flagship engineering education enterprise located in Canada Water, London. It is a clear statement about the partner universities’ commitment to innovation. It sits alongside collaborative research that champions interdisciplinarity and game-changing programs for digital learners. At every turn, our mission is to collaborate with industry, government, communities and, where feasible, other higher-education providers.



Mr Paul Ramadge, Managing Director

CELEBRATING THOSE WHO DARE TO DREAM

Great universities are hot-beds of ideas and interactions. The PLuS Alliance is fortunate to draw together three universities which not only excel in these pursuits but share a bigger vision to tackle the most pressing problems of the globe. The challenges, as shown by the COVID-19 pandemic, are becoming more complex and more unpredictable, which has reinforced the PLuS Alliance’s commitment to bring the very best minds together to think in new ways. It is an exciting venture built on collaboration and enterprise. The PLuS Alliance experiments, seeks higher levels of knowledge, challenges traditional ways of doing things, and reaches out to industry, government and communities to better understand and be able to respond to societal needs. This publication celebrates the work of those who have dared to dream in the PLuS Alliance’s start-up years. Our ambition is to generate greater impact in the years ahead.



Professor Sir Malcolm Grant, Chair, Governance Board and Advisory Board

OUR STRATEGIC PRIORITIES AND TEAM



EDUCATION

Access to quality education at scale



RESEARCH

Collaborative research with global impact



ENGAGEMENT

Engagement with influence

GOVERNANCE BOARD

Professor Sir Malcolm Grant, Chancellor of York University and global higher education adviser (Chair)

Professor Michael Crow, President, Arizona State University

Professor Shitij Kapur, Principal and President, King's College London

Professor Ian Jacobs, Vice-Chancellor and President, UNSW Sydney

Professor Mark Searle, Executive Vice-President and Provost, Arizona State University

Professor Evelyn Welch, Provost/Senior Vice President (Arts & Sciences), King's College London

Professor Nick Fisk AM, Deputy Vice-Chancellor (Research), UNSW Sydney

INTERNATIONAL ADVISORY BOARD

Professor Sir Malcolm Grant (Chair)

Dr Ellen Levy (USA)

The Rt Hon. Charles Clarke (UK)

Dr Gail Kelly (Australia)

FELLOWS

More than 130 leading researchers and educators at Arizona State University, King's College London and UNSW Sydney have been appointed as PLuS Fellows to champion collaborative research, education and help lead major initiatives.



Dr Ellen Levy



The Rt Hon. Charles Clarke



Dr Gail Kelly



Dr Eka Ikpe, PLuS Fellow,
King's College London



Professor Matthew Scotch and
Professor Dave White,
PLuS Fellows, ASU



Flagship engineering education enterprise

In March 2020, the PLuS Alliance formally launched TEDI-London, a joint-venture engineering education enterprise designed to address gaps in international engineering skills and diversity, via an innovative approach to curriculum delivery, industry partnerships and student recruitment. When TEDI-London is fully operational in 2021, students will work through real-life industry projects from a bespoke engineering campus at Canada Water, London. Their project-based learning will be supported by a cutting-edge virtual learning system and an international team of mentors, experts and coaches from across academia and business. TEDI-London aims to disrupt traditional entry requirements and is designed to meet the interests of applicants from diverse educational backgrounds.

“Our vision is to transform engineering education to transform lives – both for those who study with us, and for those who benefit from the solutions our students will design and make for a global society.”

PROFESSOR JUDY RAPER AM, FOUNDING DEAN AND CEO



SUMMER SCHOOL 2019 ON LOCATION

Innovative designs by students from the PLuS partner universities

25

students

3

projects

SUMMER SCHOOL 2020 VIRTUAL

Designing solutions for a dementia-friendly community

147

students

21

nations



WEBSITE

tedi-london.ac.uk



LINKEDIN

@TEDI-London



INSTAGRAM

@tedi_london

INDUSTRY PARTNERS

“We are really excited about this partnership with TEDI-London. It is a genuinely unique education program looking to address the skills gap in the engineering sector.”

ROGER MADELIN, JOINT HEAD OF CANADA WATER, BRITISH LAND

COLLABORATIVE RESEARCH

Outstanding researchers from Arizona State University, King's College London and UNSW Sydney collaborate to pursue solutions to some of the world's most pressing challenges, underpinned by the United Nations Sustainable Development Goals (UNSDGs). The researchers focus primarily on four themes.



SUSTAINABILITY

Research balances the need to innovate and progress as a global society while respecting the limits of the world's natural resources.

GLOBAL HEALTH

Research addresses persistent and emerging health issues for individuals and their communities.



SOCIAL JUSTICE

Research defines and reduces societal roadblocks in pursuit of a peaceful and prosperous coexistence.

TECHNOLOGY AND INNOVATION

Research expands technological and scientific breakthroughs for the well-being of the global society.



SUSTAINABILITY

The brick that creates light

Access to electricity in buildings is still a global challenge, especially in undeveloped countries. Light at night is known to significantly enhance productivity and education.

A PLoS Alliance team of researchers – Dr Leigh Aldous (King’s College London), Professor Patrick Phelan (ASU) and Associate Professor Robert Taylor (UNSW Sydney) – have created a thermogalvanic brick that generates electricity. This is due to balanced electrochemical reduction and oxidation processes occurring inside the brick at the two faces. If electrodes at these faces are at different temperatures, electrochemical reactions occur and electricity is generated. For example, if a house or shelter’s outside wall is sunny and hot but the interior is shaded and cool then electricity can be produced by the wall. The compounds inside are not consumed, do not run out and can never be overcharged.

By using gelled water inside the brick and adding a 3D printed interior based upon a Schwarz D minimum surface structure, the thermogalvanic bricks are stronger than household bricks and can also improve insulation.

The research team has filed a provisional patent for the bricks, which could be 3D printed from recycled plastic and used quickly and easily to make something like a refugee shelter.



Associate Professor Robert Taylor from UNSW (top), Dr Leigh Aldous from King’s (Middle) and Professor Pat Phelan and Benjamin Obeng from ASU



VIDEO

<https://www.youtube.com/watch?v=EcErIHvj08>

“We brought together the solar radiation and energy expertise of researchers at UNSW, the expertise in sustainability and building practices from ASU and at King’s we were able to contribute our thermogalvanic knowledge to make the bricks functional. This project would not have existed without the PLoS Alliance”.

RESEARCHER DR LEIGH ALDOUS, KING’S COLLEGE LONDON

Anthropocene research

Humanity's role in shaping Earth's bio-geo-chemical systems is exploding, so much that many researchers suggest that we have entered a new geological epoch, the Anthropocene.

In essence, humans create many problems but provide the best and probably only source of potential solutions to them. This PLoS Alliance research collaboration centres on the important roles that the humanities play in better understanding and addressing these issues.

There is growing recognition that sustainability science requires input from scholars rooted in human values, ethics, cultures, aesthetics and imaginations, in addition to physical scientists and engineers. The research aims to foster meaningful and deep collaborations between humanists and sustainability scientists in three interlinking areas for which all three PLoS Alliance institutions are considered to be world leaders: climate and society, biodiversity and indigenous knowledges. The goal is to develop and pilot environmental humanities applications to solve pressing global challenges.

Researchers:

Professor Gary Dirks (ASU)
 Associate Professor Rimjhim Aggarwal (ASU)
 Professor Joni Adamson (ASU)
 Dr George Adamson (King's College London)
 Professor Cameron Holley (UNSW)

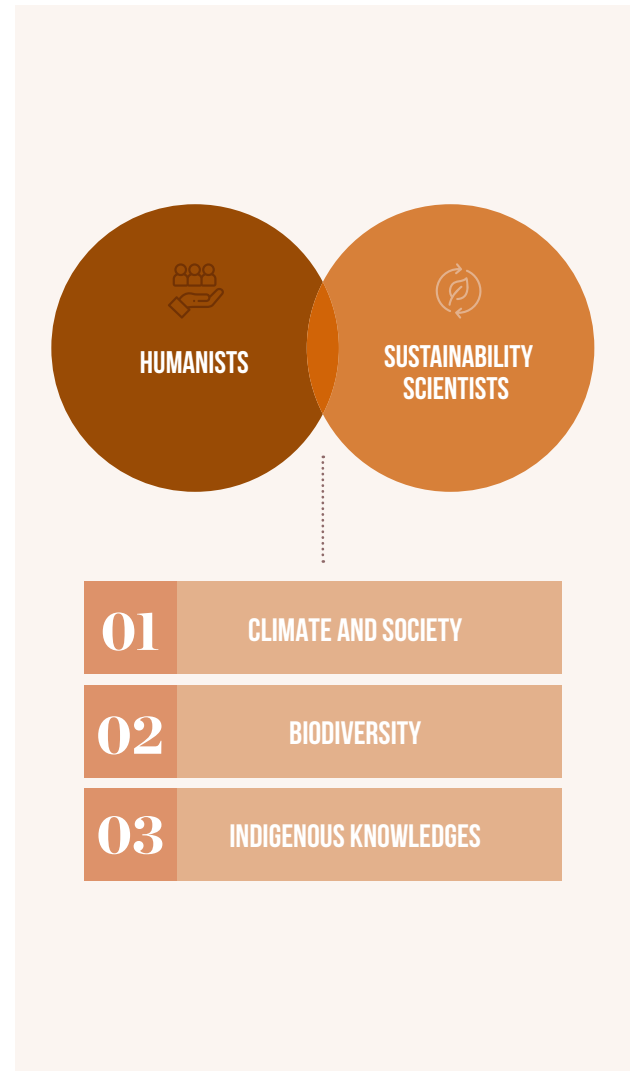

GLOBAL HEALTH

Front-line research on biosecurity and infectious diseases

PLuS Alliance researchers were at the forefront of global research in biosecurity well before the COVID-19 pandemic. In 2016, Raina MacIntyre – Professor of Infectious Disease Epidemiology at UNSW Sydney and a PLuS Alliance Fellow – conceived of a mini film series called *Pandemic* as a teaching aid for her online course on Bioterrorism and Health Intelligence. The film series became part of a suite of Global Health programs offered by the PLuS Alliance.

In addition, teams of researchers across the PLuS partner universities have collaborated in other ways to save lives and improve public awareness of biosecurity risks. For example:

- Professor MacIntyre worked with Associate Professor David Heslop from UNSW Sydney, Associate Professor Brian Gerber from Arizona State University and US Indo-Pacific Command in Hawaii to hold an immersive simulation in December 2019 of a multi-threat bioterrorism disaster. The exercise was attended by more than 200 key government and non-government stakeholders from the US, UK, Canada, Australia, New Zealand and the Indo-Pacific region.
- Researchers Professor MacIntyre, Professor Matthew Scotch (ASU) and Dr Kathleen Steinhöfel (King's College London) have collaborated to investigate H5N1 avian influenza and the risk factors for human-to-human forms of the highly pathogenic virus.



Professor Raina MacIntyre



VIDEO

<https://www.youtube.com/watch?v=bVvUGWkHIUQ&t=14s>



A panel presentation at the Pacific Eclipse conference in December 2019 (Photo: Capt Andy Green (UK Army), Dr Gina Samaan (WHO), Major Kat Hoedjke (Northcom), Professor Luca Vigano (King's))

Smartphone blood-iron analyser

Iron deficiency, a leading cause of anaemia, is one of the world's major nutritional disorders, according to the World Health Organisation (WHO). A target has been set for a 50% reduction of anaemia in women of reproductive age by 2025. It is estimated by WHO that one in four people globally suffer from anaemia. Hemochromatosis is another blood disorder associated with excess iron that is usually diagnosed late in the stages of irreversible organ damage. It is a genetic condition, with an incidence of one in 200 people of northern European origin.

Dr Erica Forzani and Professor N.J. Tao at ASU, along with post-doctoral researcher Michael Serhan at ASU and Professor Wolfgang Maret and Dr Ismael Diez Perez at King's College London, have been working on low-cost point-of-care (POC) technology. They have been concentrating on the development of novel hybrid sensors and their integration into wireless, passive and inexpensive medical devices such as mobile phones. The devices will then measure blood-iron markers, with the goal of both preventing and treating iron related disorders.

The team has achieved significant milestones in terms of the method of assessment. A smartphone mount has been created that is robust and controls the light source of a colour-reading app, which is calibrated to obtain iron-concentration results. A dry-sensor strip includes membranes that are sandwiched vertically and compressed to ensure proper drawing and absorption of the fluid sample through the membranes as well as separating cellular components of the blood via porosity.

The smartphone application could dramatically lower costs associated with blood-iron tests because there are fewer interventions – a clear benefit in both developed and developing nations. The smartphone mount costs about US\$13; the sensor strip about US\$0.06.

With the application, a physician can access data quickly and make a judgement about whether further consultations are needed, reducing any unnecessary burden on the patient.

The next step is to conduct a pilot study on a group diagnosed with iron-deficiency anaemia as well as a cohort diagnosed with hemochromatosis. The tests will try to identify correlations between each sub-group and iron levels in real time.

In those parts of the world where people have a smartphone, a range of reasons could impact one's ability to get a test – for example, poor infrastructure, work and care responsibilities, hospital policies regarding the number of times blood can be tested, time-consuming and invasive blood tests and COVID-19 restrictions. The smartphone app could be a gamechanger. Iron levels can be tracked so that the disease can be managed better, before it gets to a critical point. The new method can provide accurate results in intra-laboratory and inter-laboratory verification, improve mobility and lower costs – key drivers to improve global healthcare.



Dr Erica Forzani

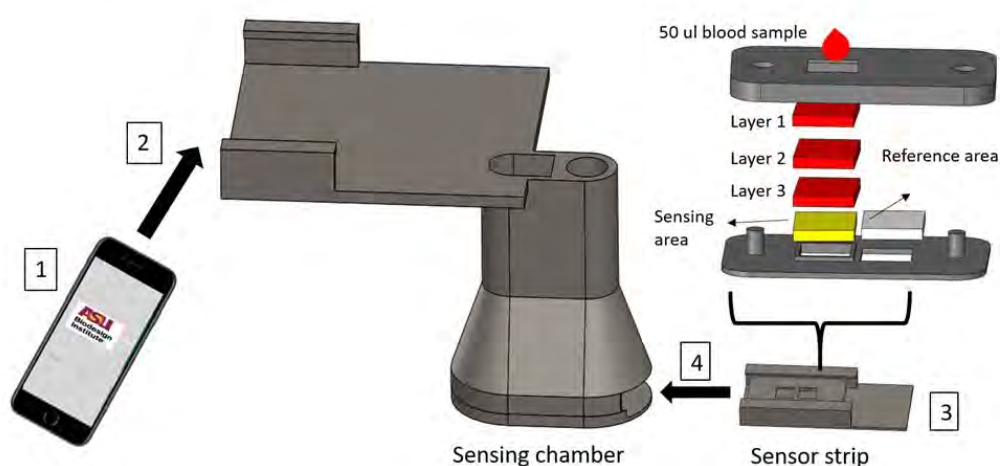

SOCIAL JUSTICE

Women's leadership



While gender equality is improving in higher education institutions, professions and industry, globally women are under-represented among CEOs, board and executive members of major companies, professors and political leaders. The PLuS Alliance is setting out to make a sustainable difference.

In 2020, the Transforming Women's Leadership Pathways (TWLP) initiative was launched, bringing together opinion-shaping women and men to examine evidence on the critical factors that limit women's pathways to senior leadership in their fields, and to develop action plans that articulate the practical actions that government, universities and industry must take to close the leadership gender gap and expand leadership pathways.

More than 100 leaders and students from universities, government and industry took part in the initial TWLP event. They worked in ten groups – Arts, Corporate, Engineering, Entrepreneurship and Innovation, Higher Education, Media and Communications, Medicine and Life Sciences, Policy and Politics, Science, and Technology – to develop bold action plans aimed at establishing gender parity, equity and diversity as the norm by 2030.

Each group tested their recommendations against the principles of intersectionality, sustainability and changing work patterns to ensure that the solutions are inclusive and

This landmark initiative has led to the creation of the Global Alliance for Equity in Leadership (GAEL) launched in March 2021.

GAEL aims to be a global source of evidence-based solutions, trusted communication and proven strategies on equitable leadership practices, and a platform for developing a generation of diverse women leaders.



[GAEL2030](#)

EMERGING THEMES



MENTAL HEALTH

Over the coming decades the world will face a wide range of complex, new and persistent public mental health challenges, exacerbated by events such as the COVID-19 pandemic. A research team led by King's College London, drawn from one of the world's most exceptional clusters of psychiatrists, clinicians, methodologists, epidemiologists and cross-disciplinary researchers, is exploring life transitions during adolescence, young adulthood, working life and beyond. The focus is on the prevention, early detection and intervention of common mental disorders, including suicide and self-harm. The vision is to contribute to a transformational change in public mental health.

ADDICTIONS

Tobacco, alcohol and other drug addictions or misuse are substantial contributors to the global burden of disease and the cost of associated health outcomes. PLuS Alliance researchers, led by UNSW Sydney and including some of the world's leading practitioners, are setting out to create a step-change in the prevention and/or treatment of alcohol and drug use. The team is aiming to deliver effective interventions that are not currently delivered at levels to produce achievable health gains. The research teams will explore the impact of Covid-19 on substance use as well as addictions affecting Indigenous communities.



VETERANS

This research focuses on the health and wellbeing of returned service personnel from the United States, the United Kingdom, Australia, Canada and New Zealand. Many are impacted in multiple ways, from traumatic brain injury to PTSD, depression and anxiety, substance abuse, homelessness and increased risk of suicide. The objective is to examine experiences in accessing services to identify best practices and to cross-fertilise the most promising approaches for veterans and their families.

EDUCATION

A fully online international public health degree

The online Bachelor of International Public Health (BIPH), jointly developed by the PLuS partners, embodies a core principle – to develop solutions to global public health challenges. The innovative program is a direct response to calls from the United Nations for countries to scale up transformative, high-quality education in the public health space to deal with a projected shortfall of 18 million public health workers by 2030. The program is designed as a direct pathway into a career in public health, to build and strengthen the international public health workforce.



The degree prepares students to design and implement new approaches to emerging global and public health issues, including prevention, public health surveillance, health promotion, communicable and non-communicable diseases, environmental health, and global health systems. Students interact on a global basis throughout the program with fellow students and academics at the PLuS universities, growing their global knowledge base and interpersonal skills to impact an increasingly connected world on health.



GLOBAL LEARNING



FLEXIBLE PROGRAM



FULL TIME OR PART-TIME



INDUSTRY PARTNERS

“This program is ideal for undergraduate students who want to make a difference. It provides the extraordinary opportunity to learn about global public health while interacting with students and academics across the world.”

DR LOIS MEYER, UNSW SYDNEY

Career pathways in:

- EPIDEMIOLOGY
- HEALTH PROTECTION
- HEALTH PROMOTION
- DISEASE PREVENTION
- HEALTH SYSTEMS



GLOBAL ENGAGEMENT



BOTSWANA CLOSE UP

One of the world's most spectacular eco-systems – the Okavango Delta in Botswana – has become an invaluable learning experience for students taking part in a PLuS Alliance study abroad program. The annual program offers students the opportunity to conduct practical field-research in the UNESCO World Heritage Site and learn about the global challenges of water conservation and governance.

In the program, led by a team of experts from the three PLuS universities, students meet peers from partner universities, take part in lectures on transboundary river basin management and explore social-ecological relationships. They venture to a research camp run by NGO partner Elephants Without Borders where they survey water quality, vegetation and other organisms, and set up camera traps. The delta is rich in wildlife, including elephants, buffalo, warthogs, baboons, hippos and water-birds, adding to the students overall experience and knowledge about the impact of the delta.

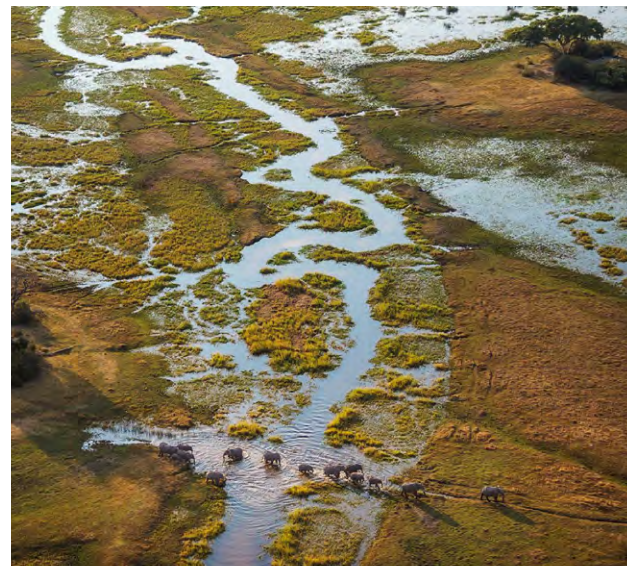



Africa roundtable meeting at King's College London - February 2020

AFRICA

The PLuS Alliance has begun a journey to build deep, substantive and mutually beneficial relationships with peer institutions in Sub-Saharan Africa, informed by a belief that partnership is based upon negotiation, collaboration and cooperation. Working alongside the African Research Universities Alliance (ARUA) and four of their member institutions – University of Nairobi (Kenya), Makerere University (Uganda), Ibadan University (Nigeria) and University of Ghana (Ghana) - our current area of focus is how to contribute to the development of robust R&D ecosystems to underpin future prosperity.

INDIA

An agreement has been signed with the Pune Smart City Development Corporation Limited to advance research, education and outreach projects that address pressing urbanisation challenges in one of the largest cities in India. Under the agreement, the PLuS Alliance will collaborate on activities including identifying specific research projects, designing education programs, and securing business, government and industry sponsors. Pune is the second-largest city in the Indian state of Maharashtra and is the ninth most populous city in the country, with an estimated population of 3.13 million.



Dr Simone Zarpelon Leao (UNSW), Professor Ian Jacobs (UNSW), Manojit Bose (Chief Knowledge Officer of Pune Smart City) and Vinita Chanan (UNSW).

DIGITAL INNOVATIONS

Improving the student experience through flexible technology-enabled learning is the cornerstone of the PLuS Alliance's approach to education.

Academics from the three partner universities have collaborated to develop individual courses in health management and behavioural health, nuclear power, sustainability engineering, special education, geography and urban planning. Multiple courses have been provided in cybersecurity and biosecurity, and full degrees include the Bachelor of International Public Health and the Master of International Health Management.

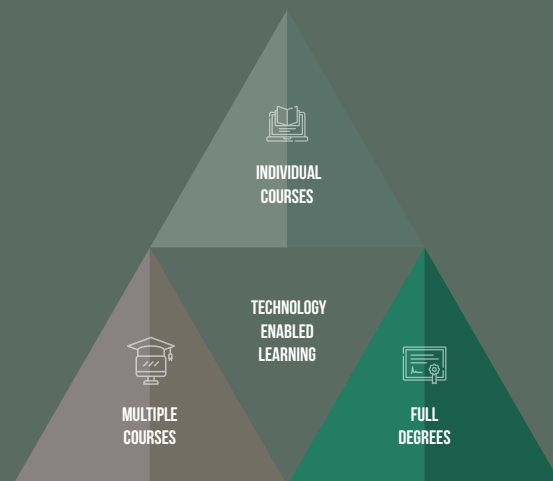

CELEBRATING EXCELLENCE

THE PLuS ALLIANCE PRIZE

In 2017 the PLuS Alliance Prize celebrated the achievements of remarkable educators, researchers and leaders from around the world, working in pursuit of the same aims as the PLuS Alliance. The awards drew an outstanding list of nominations, all with demonstrated excellence in addressing the greatest global challenges facing society. The winners were:

EDUCATION INNOVATION

Professor Laura Hosman for The Solar Powered Educational Learning Library (SolarSPELL), designed to deliver curated content to remote, unconnected regions



RESEARCH INNOVATION

Professor Veena Sahajwalla for the new science of green manufacturing, which advocates ways in which global industries can use green materials instead of virgin raw materials to improve sustainability



GLOBAL LEADERSHIP

Mr Narayana Murthy for his vision in bringing a powerful IT wave to India, his philanthropy and his thought-leadership



GLOBAL INNOVATION

Professor Francisco Mojica for the advent of CRISPR gene editing, which has been heralded as one of the most significant advances in the life sciences



PLUS ALLIANCE

PHOENIX | LONDON | SYDNEY

Respect | Integrity | Collaboration | Inclusion | Innovation | Courage

Website	https://www.plusalliance.org/
Research Projects	https://www.plusalliance.org/plus-research-projects#
Managing Director	paul.ramadge@plusalliance.org
Program Manager	jo.griffiths@plusalliance.org
Communications Officer	olabisi.olulode@plusalliance.org
PLuS Alliance ASU	janice.kleinwort@asu.edu
PLuS Alliance King's	jen.angel@kcl.ac.uk
PLuS Alliance UNSW	info.PlusAlliance@unsw.edu.au